

EDR

(JIS 名称 : JCR)
光学用ミラー付タイプ



GX5.3 Base

品名	定格電圧 (V)	消費電力 (W)	寸法 (mm) Max.			ワキワキ径 [WD] (mm)	色温度 (K) 参考値	定格寿命 (h)	点灯方向	Fig.No.
			ミラー径 (A)	全長 (B)	ワキワキ径 [WD] (mm)					
* EKZ 10.8V 30W	10.8	30	50.7	44.5	38.1	3100	200	BD/HOR	1	
* EPN 12V 35W	12	35	50.7	44.5	29	3300	50	BD/HOR	1	
* EPT 10.8V 42W	10.8	42	50.7	44.5	38.1	2900	8000	BD/HOR	1	
* ENZ 30V 50W	30	50	50.7	44.5	29	3400	25	BD/HOR	1	
* ENW 19V 80W	19	80	50.7	44.5	44.5	3200	200	BD/HOR	1	
* DDL 20V 150W	20	150	50.7	44.5	194.5	3150	500	BD/HOR	1	
* EKE 21V 150W	21	150	50.7	44.5	44.5	3250	200	BD/HOR	1	
* EJV 21V 150W	21	150	50.7	44.5	44.5	3400	40	BD/HOR	1	
* JER 100V 150W D2	100	150	50.7	44.5	31.7	-	50	BD/HOR	1	
* EJL 24V 200W	24	200	50.7	44.5	31.7	3400	50	BD/HOR	1	
* ELC 24V 250W	24	250	50.7	44.5	31.7	3400	50	BD/HOR	1	
* ELC/5 25V 250W	25	250	50.7	44.5	31.7	3400	50	BD/HOR	1	

GY5.3 Base

品名	定格電圧 (V)	消費電力 (W)	寸法 (mm) Max.			ワキワキ径 [WD] (mm)	色温度 (K) 参考値	定格寿命 (h)	点灯方向	Fig.No.
			ミラー径 (A)	全長 (B)	ワキワキ径 [WD] (mm)					
* ESJ 82V 85W	82	85	50.7	44.5	32	-	40	BD/HOR	2	
* ESD 120V 150W	120	150	50.7	44.5	44.5	3350	12	BD/HOR	2	
* EYA 82V 200W	82	200	50.7	44.5	38.1	3300	50	BD/HOR	2	
* ENH 120V 250W	120	250	50.7	44.5	152.4	3250	175	BD/HOR	2	
* EDR 100V 300W	100	300	50.7	44.5	152.4	3350	35	BD/HOR	2	
* ELH 120V 300W	120	300	50.7	44.5	152.4	3350	35	BD/HOR	2	

* 印製品はロット受注生産品です。

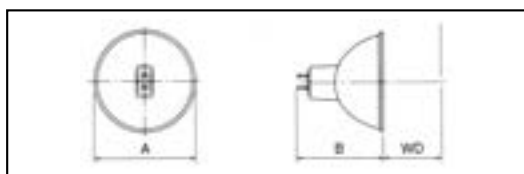

Fig-1

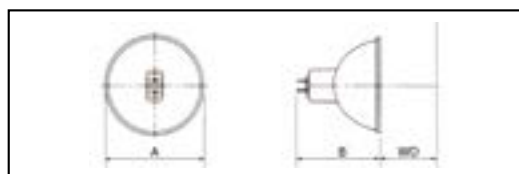
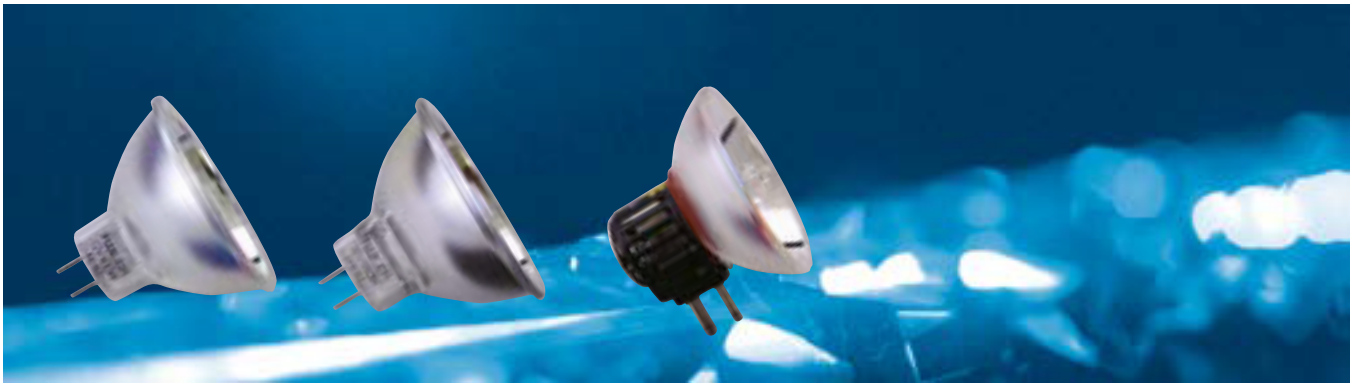

Fig-2



GX6.35 Base

寸法 (mm) Max.

品名	定格電圧 (V)	消費電力 (W)	ミラー径 (A)	全長 (B)	フーキング径 [WD] (mm)	色温度 (K) 参考値	定格寿命 (h)	点灯方向	Fig.No.
* EFM 8V 50W ※	8	50	50	42	32	3350	50	BD/HOR	3
* EFM/D 8V 50W	8	50	50	42	32	3350	50	BD/HOR	3
* JCR 12V 50W H20	12	50	50	42	32	3000	2000	BD/HOR	3
* EFN 12V 75W	12	75	50	42	32	3400	50	BD/HOR	3
EFP 12V 100W	12	100	50	42	32	3400	50	BD/HOR	3
JCR 12V 100W H10	12	100	50	42	32	3100	1000	BD/HOR	3
JCR 15V 150W H5	15	150	50	42	36	3100	500	BD/HOR	3
EFR 15V 150W	15	150	50	42	32	3400	50	BD/HOR	3
* JCR 15V 150W H5 AL ※	15	150	50	42	36	3100	500	BD/HOR	3
JCR15V 150W AL ※	15	150	50	42	32	3400	50	BD/HOR	3

※アルミコーティングミラー

GX7.9 Base

寸法 (mm) Max.

品名	定格電圧 (V)	消費電力 (W)	ミラー径 (A)	全長 (B)	フーキング径 [WD] (mm)	色温度 (K) 参考値	定格寿命 (h)	点灯方向	Fig.No.
* DNF 21V 150W	21	150	57.2	45.1	69.1	3400	25	HORIZ	4

※ 印製品はロット受注生産品です。

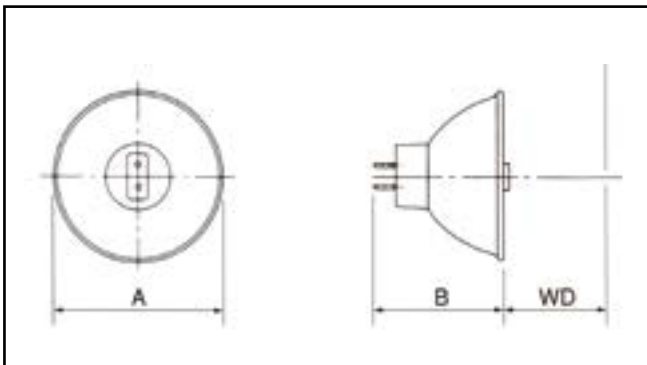

Fig-3

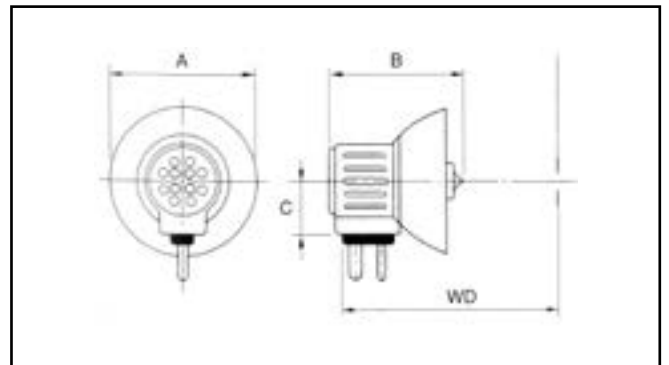

Fig-4

JC

光学用シングルコイルタイプ



G4 Base

寸法 (mm)

品名	ANSI	定格電圧 (V)	消費電力 (W)	A(Max.)	B(Max.)	C	全光束 (lm)	色温度 (K) 参考値	定格寿命 (h)	フィラメントタイプ	Fig.No.
* JC 6V 10W M	ESA/FHD	6	10	9	30	19.5	200	3200	100	C-6	1
* JC 6V 20W M	ESB/FHE	6	20	9	30	19.5	450	3200	100	C-6	1

G6.35 Base

寸法 (mm)

品名	ANSI	定格電圧 (V)	消費電力 (W)	A(Max.)	B(Max.)	C	全光束 (lm)	色温度 (K) 参考値	定格寿命 (h)	フィラメントタイプ	Fig.No.
* JC 12V 50W	BRL/BCD	12	50	11.5	44	30	1400	3300	50	CF-6	1
JC 24V 150W	FCS	24	150	13.5	50	30	5000	3400	50	CF-6	1
* FDV 24V 150W	FDV	24	150	13.5	50	30	4300	3300	100	CF-6	1
JC 24V 250W	EHJ	24	250	13.5	55	33	8500	3400	50	CF-6	1
* JC 25V 250W		25	250	13.5	56	33	8500	3400	50	CF-6	1
* EVD 36V 400W	EVD	36	400	18	60	36	16000	3450	50	CF-6	1

* 印製品はロット受注生産品です。

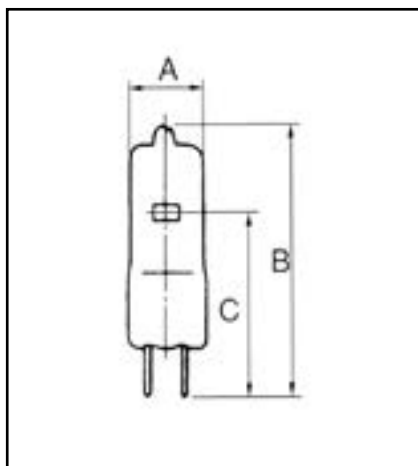

Fig-1



G6.35 Base20 × 19

寸法 (mm)

	品名	ANSI	定格電圧 (V)	消費電力 (W)	A(Max.)	B(Max.)	C	全光束 (lm)	色温度 (K) 参考値	定格寿命 (h)	フィラメントタイプ	Fig.No.
*	JC 12V 50W L		12	50	13	60	36	1300	3300	50	CF-6	2
*	JC 12V 100W L		12	100	10.5	60	36	2900	3300	50	CF-6	2
*	JC 24V 50W L		24	50	10.5	60	36	1300	3200	100	CF-6	2
*	JC 24V 75W L		24	75	14	60	36	2000	3250	50	CF-6	2
	JC 24V 100W L		24	100	13	60	36	2900	3300	50	CF-6	2
	JC 24V 150W L		24	150	13.5	61	37	4800	3400	50	CF-6	2
*	JC 24V 250W L		24	250	13.5	63	37	8500	3400	50	CF-6	2

GY6.35 Base

寸法 (mm)

	品名	ANSI	定格電圧 (V)	消費電力 (W)	A(Max.)	B(Max.)	C	全光束 (lm)	色温度 (K) 参考値	定格寿命 (h)	フィラメントタイプ	Fig.No.
*	JC 12V 100W	FCR	12	100	11.5	44	30	3400	3300	50	CF-6	3
*	JC 24V 300W S		24	300	13.5	55	33	9900	3400	50	CF-6	3

GY9.5 Base

寸法 (mm)

	品名	ANSI	定格電圧 (V)	消費電力 (W)	A(Max.)	B(Max.)	C	全光束 (lm)	色温度 (K) 参考値	定格寿命 (h)	フィラメントタイプ	Fig.No.
*	JC 28V 300W C/C		28	300	15	60	36.5	9600	3400	50	CF-6	4

* 印製品はロット受注生産品です。

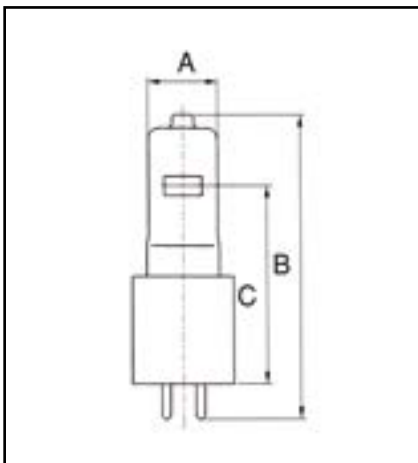

Fig-2

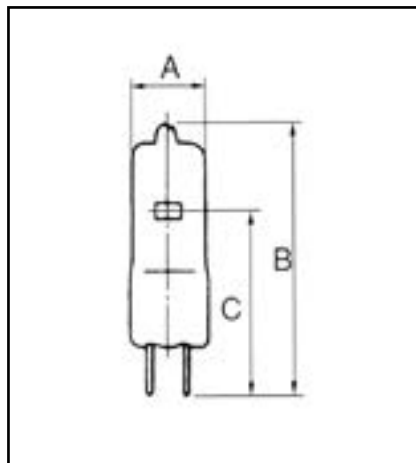

Fig-3

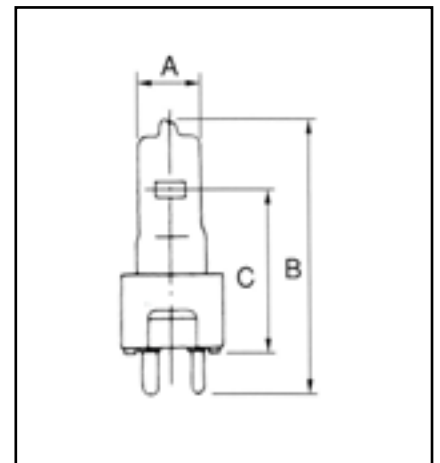

Fig-4

JCD

光学用ダブルコイルタイプ



G5.3 Base

寸法 (mm)

品名	ANSI	定格電圧 (V)	消費電力 (W)	A(Max.)	B(Max.)	C	全光束 (lm)	色温度 (K) 参考値	定格寿命 (h)	フィラメントタイプ	Fig.No.
* JCD 100V 500W C/LD		100	500	22	62	36.5	12500	3200	150	CC-6	1
* DVY 120V 650W	DVY	120	650	24	62	36.5	20000	3400	25	CC-6	1

G6.35 Base

寸法 (mm)

品名	ANSI	定格電圧 (V)	消費電力 (W)	A(Max.)	B(Max.)	C	全光束 (lm)	色温度 (K) 参考値	定格寿命 (h)	フィラメントタイプ	Fig.No.
* JCD 100V 100W SX		100	100	13.5	50	30	2100	3050	100	CC-6	2
* JCD 100V 150W SX		100	150	13.5	50	30	3300	3075	200	CC-6	2
* JCD 100V 250W SX		100	250	16	50	33	6000	3050	300	CC-6	2
* JCD 100V 300W SX		100	300	16	50	33	6900	3100	300	CC-6	2

G6.35 Base $\frac{15 \times 19}{20 \times 19}$

寸法 (mm)

品名	ANSI	定格電圧 (V)	消費電力 (W)	A(Max.)	B(Max.)	C	全光束 (lm)	色温度 (K) 参考値	定格寿命 (h)	フィラメントタイプ	Fig.No.
JCD 100V 200W C/L		100	200	22	63	37	5000	3200	50	CC-6	3
JCD 100V 300W C/L		100	300	22	63	37	7500	3200	150	CC-6	3
* JCD 120V 300W C/L		120	300	22	63	37	7500	3200	150	CC-6	3
* JCD 100V 500W C/L		100	500	22	63	37	12500	3200	150	CC-6	3
* JCD 100V 650W C/L		100	650	22	63	37	17750	3200	150	CC-6	3
* JCD 120V 650W C/L		120	650	22	63	37	17750	3200	75	CC-6	3

* 印製品はロット受注生産品です。

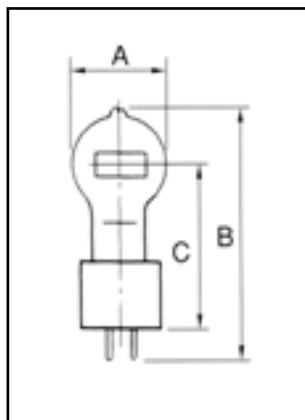

Fig-1

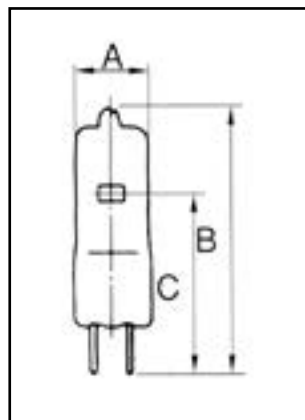

Fig-2

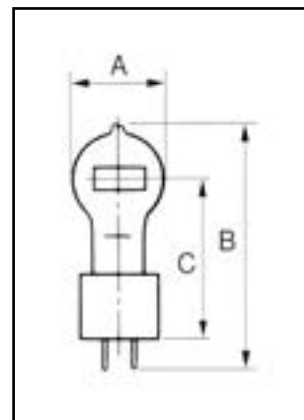

Fig-3



GX9.5 Base

寸法 (mm)

品名	ANSI	定格電圧 (V)	消費電力 (W)	A(Max.)	B(Max.)	C	全光束 (lm)	色温度 (K) 参考値	定格寿命 (h)	フィラメントタイプ	Fig.No.
JCD 100V 300W C/T		100	300	20	65	37	7500	3200	150	CC-6	7
JCD 100V 300W B/T		100	300	20	65	37	6700	3050	300	CC-6	7
JCD 100V 500W B/T		100	500	20	65	37	11000	3050	500	CC-6	7
JCD 100V 500W C/T		100	500	20	65	37	13500	3200	200	CC-6	7
* JCD 100V 650W C/T		100	650	20	65	37	16250	3200	200	CC-6	7

G9.5 Base

寸法 (mm)

品名	ANSI	定格電圧 (V)	消費電力 (W)	A(Max.)	B(Max.)	C	全光束 (lm)	色温度 (K) 参考値	定格寿命 (h)	フィラメントタイプ	Fig.No.
JCD 100V 1000W C/Z		100	1000	32	95	62	28000	3200	150	CC-6	8
JCD 100V 1000W B/Z		100	1000	32	95	62	24000	3050	800	CC-6	8

GY9.5 Base

寸法 (mm)

品名	ANSI	定格電圧 (V)	消費電力 (W)	A(Max.)	B(Max.)	C	全光束 (lm)	色温度 (K) 参考値	定格寿命 (h)	フィラメントタイプ	Fig.No.
JCD 100V 300W C/C		100	300	22	63	36.5	7500	3200	150	CC-6	9
JCD 100V 500W C/C		100	500	22	63	36.5	13000	3200	150	CC-6	9
* JCD 100V 650W C/C		100	650	22	63	36.5	17750	3200	150	CC-6	9
* JCD 120V 650W C/C		120	650	22	63	36.5	17750	3200	75	CC-6	9

* 印製品はロット受注生産品です。

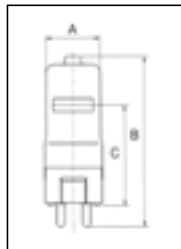

Fig-7

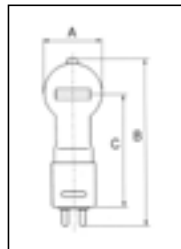

Fig-8

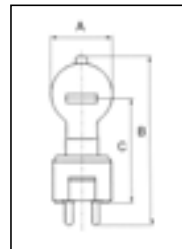

Fig-9

FCD

(JIS 名称 : JP)
ステージ・スタジオ用中型タイプ



GX9.5 Base

品名	定格電圧 (V)	消費電力 (W)	寸法 (mm)			全光束 (lm)	色温度 (K) 参考値	定格寿命 (h)	フィラメントタイプ	Fig.No.
			A(Max.)	B(Max.)	C					
FCD 100V 300W B/L	100	300	20	110	70	6600	3050	300	C-13	1
FCD 100V 500W B/SP	100	500	20	95	55	9500	3050	500	C-13	2
FCD 100V 500W C/SP	100	500	20	95	55	12000	3200	200	C-13	2
FCD 100V 500W B/L	100	500	20	110	70	11500	3050	500	C-13	1
FCD 100V 500W C/L	100	500	20	110	70	13000	3200	200	C-13	1
FCD 100V 500W B/M	100	500	34	100	55.5	11000	3050	500	C-13	3
FCD 100V 500W C/M	100	500	34	100	55.5	13500	3200	200	C-13	3
FCD 100V 500W G/D	100	500	22	105	55	12500	3125	400	C-13D	4

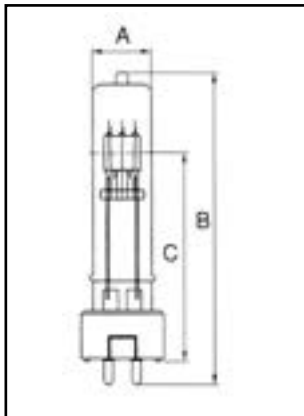

Fig-1

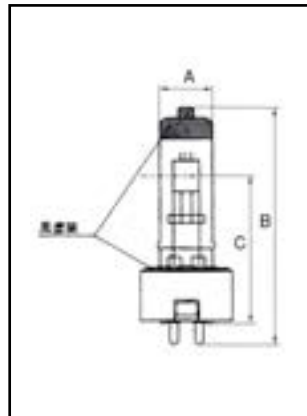

Fig-2

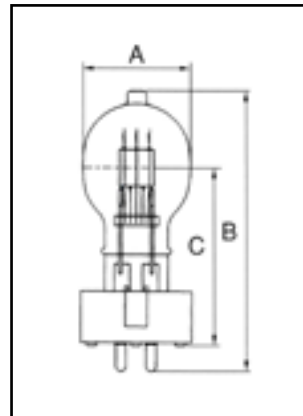

Fig-3

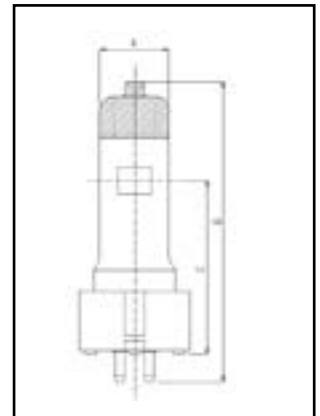

Fig-4



GY9.5(GZ9.5) Base

品名	定格電圧 (V)	消費電力 (W)	寸法 (mm)			全光束 (lm)	色温度 (K) 参考値	定格寿命 (h)	フィラメントタイプ	Fig.No.
			A(Max.)	B(Max.)	C					
FCD 100V 300W C/S	100	300	20	80	46.5	7500	3200	100	C-13	5
FCD 100V 300W B/S	100	300	15	78	46.5	6200	3100	200	C-13	5
FCD 100V 500W B/SS	100	500	20	82	46.5	11000	3050	300	C-13	5
FCD 100V 500W C/SS	100	500	20	82	46.5	13000	3200	100	C-13	5
EHA 100V 500W	100	500	19.5	76	36.5	-	3200	75	C-13D	6
* EHA 120V 500W	120	500	19.5	76	36.5	-	3200	75	C-13D	6
FCD 100V 650W C/S	100	650	20	82	46.5	16800	3200	100	C-13	5
FCD 100V 650W B/S	100	650	20	82	46.5	14300	3050	500	C-13	5
* JCP 100V 650W	100	650	19.5	76	36.5	18750	3300	75	C-13D	5
* JCP 100V 1000W	100	1000	23	95	44.5	28500	3250	100	C-13D	5

E26 Base

品名	定格電圧 (V)	消費電力 (W)	寸法 (mm)			全光束 (lm)	色温度 (K) 参考値	定格寿命 (h)	フィラメントタイプ	Fig.No.
			A(Max.)	B(Max.)	C					
FCD 100V 500W B/E2	100	500	20	115	76	11000	3050	500	C-13	7

* 印製品はロット受注生産品です。

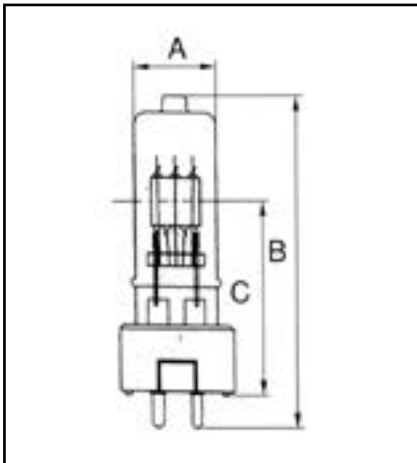

Fig-5

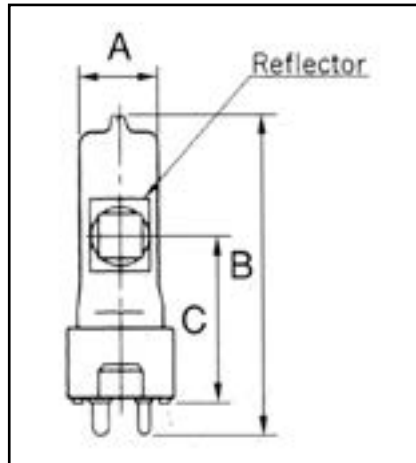

Fig-6

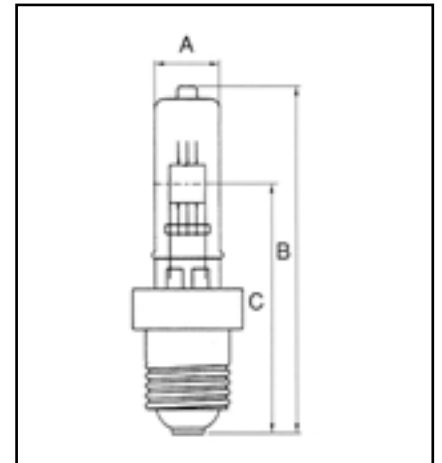

Fig-7

JS

(JIS 名称 : JP)

ステージ・スタジオ用大型タイプ



GX9.5 Base

品名	ANSI	定格電圧 (V)	消費電力 (W)	寸法 (mm)			全光束 (lm)	色温度 (K) 参考値	定格寿命 (h)	フィラメントタイプ	Fig.No.
				A(Max.)	B(Max.)	C					
* JS 100V 1000W C/T		100	1000	22	135	90	27000	3200	200	CC-8	1
* JS 100V 1000W B/T		100	1000	22	135	90	23800	3050	500	CC-8	1
* JS 100V 1000W B/U		100	1000	22	100	63.5	23000	3050	500	C-13	2
* JSH 100V 1000W B		100	1000	34	110	55	23000	3050	500	C-13	3
* JS 100V 1000W B/S2		100	1000	25	100	55	18000	3050	500	C-13D	4

GX16 Base

品名	ANSI	定格電圧 (V)	消費電力 (W)	寸法 (mm)			全光束 (lm)	色温度 (K) 参考値	定格寿命 (h)	フィラメントタイプ	Fig.No.
				A(Max.)	B(Max.)	C					
JS 100V 1000W B/M		100	1000	30	140	85	23000	3050	500	C-13	5
JS 100V 1000W C/M		100	1000	30	140	85	27000	3200	200	C-13	5
JS 100V 1000W B/MP		100	1000	30	140	85	21000	3050	500	C-13	6
JS 100V 1000W C/MP		100	1000	30	140	85	24000	3200	200	C-13	6
JS 100V 1000W G/D		100	1000	25	140	85	23300	3125	500	C-13D	7
* JS 100V 1500W B/M		100	1500	35	140	85	34500	3050	500	C-13	5
* JS 100V 1500W C/M		100	1500	35	140	85	42000	3200	200	C-13	5
* JS 100V 1500W B/MP		100	1500	35	140	85	29500	3050	500	C-13	6
* JS 100V 1500W C/MP		100	1500	35	140	85	35500	3200	200	C-13	6
* JS 100V 1500W G/D		100	1500	35	140	85	35000	3125	500	C-13D	8

* 印製品はロット受注生産品です。

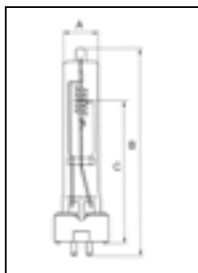

Fig-1

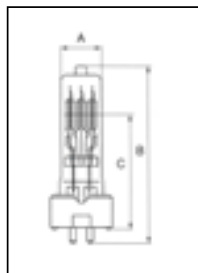

Fig-2

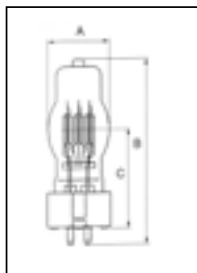

Fig-3

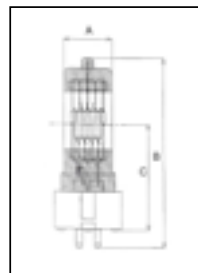

Fig-4

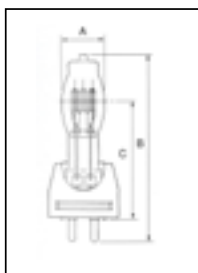

Fig-5

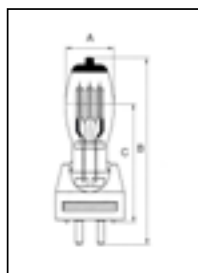

Fig-6

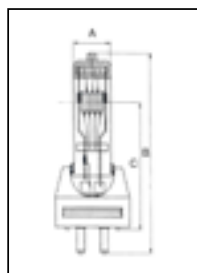

Fig-7

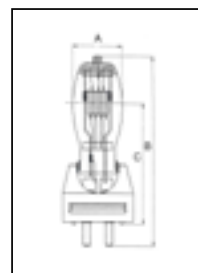

Fig-8



G22 Base

寸法 (mm)

	品名	ANSI	定格電圧 (V)	消費電力 (W)	A(Max.)	B(Max.)	C	全光束 (lm)	色温度 (K) 参考値	定格寿命 (h)	フィラメントタイプ	Fig.No.
*	JS 100V 1000W C/S1		100	1000	34	127	63.5	27000	3200	200	C-13	9
	JS 100V 1000W B/S		100	1000	34	135	75	23000	3050	500	C-13	9
	JS 100V 1000W C/S		100	1000	34	135	75	27000	3200	200	C-13	9
*	JS 100V 1500W B/S		100	1500	40	150	75	34500	3050	500	C-13	9
*	JS 100V 1500W C/S		100	1500	40	150	75	42000	3200	200	C-13	9
*	JS 100V 2000W B/S		100	2000	39	176.5	90	48000	3050	500	C-13	11
*	JS 100V 1000W BP/2		100	1000	25	150	70	21000	3050	500	C-13D	13
*	JS 100V 1500W BP/2		100	1500	25	150	70	30000	3050	500	C-13D	14
*	JS 100V 1500W CP/2		100	1500	25	150	70	35000	3200	200	C-13D	14

E39 Base

寸法 (mm)

	品名	ANSI	定格電圧 (V)	消費電力 (W)	A(Max.)	B(Max.)	C	全光束 (lm)	色温度 (K) 参考値	定格寿命 (h)	フィラメントタイプ	Fig.No.
	JS 100V 1000W B/E		100	1000	30	145	105	23000	3050	500	C-13	15
	JS 100V 1000W C/E		100	1000	30	145	105	27000	3200	200	C-13	15
	JS/S 100V 1000W C/S ※		100	1000	48	225	175	22000	3200	200	C-7A	16
	JS/S 100V 1000W C/L ※		100	1000	48	300	255	22000	3200	200	C-7A	17
	JS/SD 100V 1000W B ※		100	1000	165	360	252.5	22000	3050	400	C-7A	18
	JS/SD 100V 1000W C ※		100	1000	165	360	252.5	26000	3200	200	C-7A	18
	JS/SR 100V 1000W C		100	1000	165	360	252.5	26000	3200	200	C-7A	19
*	JS 100V 1500W B/E		100	1500	35	145	105	34500	3050	500	C-13	15

※フロストバルブ

* 印製品はロット受注生産品です。

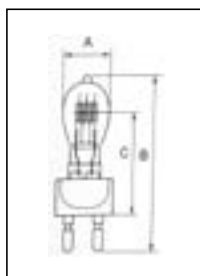

Fig-9

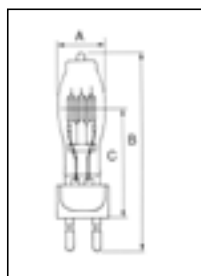

Fig-11

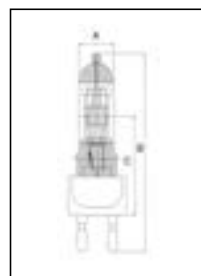

Fig-13

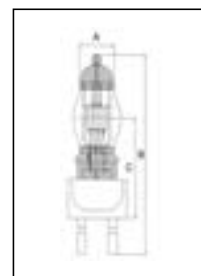

Fig-14

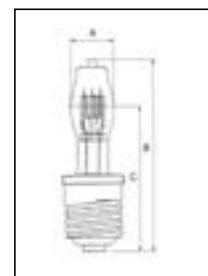

Fig-15

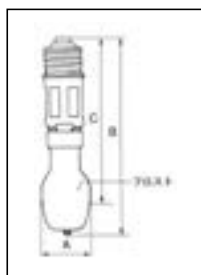

Fig-16

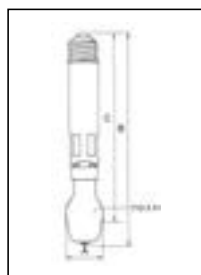

Fig-17

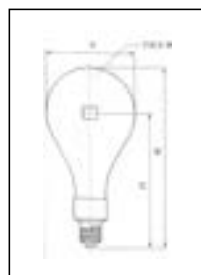

Fig-18

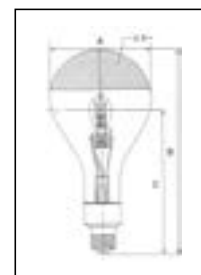

Fig-19



G38 Base

品名	ANSI	定格電圧 (V)	消費電力 (W)	寸法 (mm)			全光束 (lm)	色温度 (K) 許値	定格寿命 (h)	フィラメントタイプ	Fig.No.
				A(Max.)	B(Max.)	C					
* JS 120V 1000W C/L	CYV	120	1000	22	197	127	27500	3200	200	C-13D	20
* JS 100V 1500W C/L		100	1500	35	197	127	42000	3200	200	C-13	20
* JS 100V 1500W B/L		100	1500	35	197	127	34500	3050	500	C-13	20
* JS 120V 1500W C/L	CXZ	120	1500	35	203.2	127	38500	3200	300	C-13D	20
JS 100V 2000W B/L		100	2000	45	210	127	48000	3050	500	C-13	20
JS 100V 2000W C/L		100	2000	45	210	127	58000	3200	200	C-13	20
* JS 120V 2000W	CYX	120	2000	45	215.9	127	59000	3200	250	C-13	20
* JS 220V 2000W		220	2000	45	215.9	127	52000	3200	300	C-13	20
* JS 240V 2000W		240	2000	45	215.9	127	52000	3200	300	C-13	20
* JS 100V 3000W B/M		100	3000	50	210	127	69000	3050	500	C-13	20
JS 100V 3000W C/M		100	3000	50	210	127	78000	3200	200	C-13	20
* JS 120V 3000W C/M		120	3000	50	210	127	78000	3200	300	C-13	20
* JS 220V 3000W C/M		220	3000	50	220	127	78000	3200	300	C-13	20
JS 100V 5000W B		100	5000	60	268	165	115000	3050	600	C-13	21
JS 100V 5000W C		100	5000	60	268	165	145000	3200	500	C-13	21
* DPY 120V 5000W	DPY	120	5000	60	268	165	140000	3200	500	C-13	21
* JS 220V 5000W		220	5000	60	268	165	135000	3200	400	C-13	21
JS 100V 10000W C		100	10000	80	400	254	290000	3200	300	C-13	22
* DTY 120V 10000W	DTY	120	10000	80	400	254	285000	3200	300	C-13	22
* JS 220V 10000W		220	10000	80	400	254	285000	3200	300	C-13	23
* JS 240V 10000W		240	10000	80	400	254	285000	3200	300	C-13	23
* JS 200V 20000W C		200	20000	130	560	354	580000	3250	300	C-13	24
* JS 200V 24000W C		200	24000	130	560	354	696000	3250	300	C-13	24

* 印製品はロット受注生産品です。

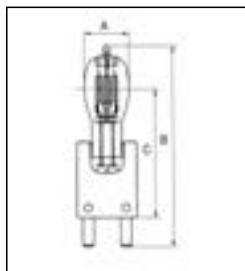

Fig-20

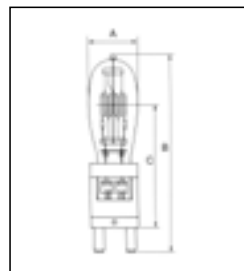

Fig-21

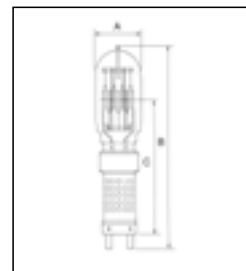

Fig-22

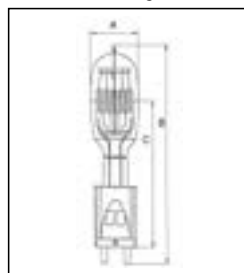

Fig-23

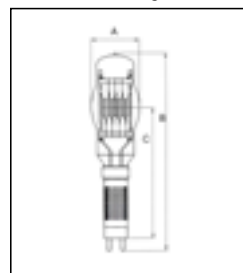

Fig-24

JD

一般・スタジオ・ステージ用



E11 Base

品名	定格電圧 (V)	消費電力 (W)	寸法 (mm)			全光束 (lm)	色温度 (K) 参考値	定格寿命 (h)	フィラメントタイプ	Fig.No.
			A(Max.)	B(Max.)	C					
JD 110V 100W M	110	100	11.5	70	49	1600	2900	1500	CC-8	1
* JD 110V 100W MF ※	110	100	11.5	70	49	1520	2900	1500	CC-8	1
JD 110V 150W M	110	150	14	70	49	2400	2900	1500	CC-8	1
JD 110V 200W M	110	200	14	75	49	3400	2900	2000	CC-8	1
* JD 110V 200W MF ※	110	200	14	75	49	3230	2950	2000	CC-8	1
* JD 110V 250W MF ※	110	250	14	81	61	4280	2900	2000	CC-8	1
JD 110V 250W M	110	250	14	81	61	4500	2900	2000	CC-8	1
JD 110V 300W M	110	300	14	81	56	5400	2950	2000	CC-8	1
JD 110V 500W M	110	500	14	95	66	9500	2950	2000	CC-8	1

※フロストパブル

G9.5 Base

品名	定格電圧 (V)	消費電力 (W)	寸法 (mm)			全光束 (lm)	色温度 (K) 参考値	定格寿命 (h)	フィラメントタイプ	Fig.No.
			A(Max.)	B(Max.)	C					
JD 100V 500W C/Z	100	500	15	93	60	13000	3200	200	CC-8	2
JD 100V 750W B/Z	100	750	19.5	103	60	15800	3050	1500	CC-8	2
JD 100V 750W C/Z	100	750	19.5	103	60	18000	3150	300	CC-8	2
JD 100V 1000W B/Z	100	1000	19.5	103	60	21000	3050	1500	CC-8	2
JD 100V 1000W C/Z	100	1000	19.5	103	60	27000	3200	200	CC-8	2

* 印製品はロット受注生産品です。

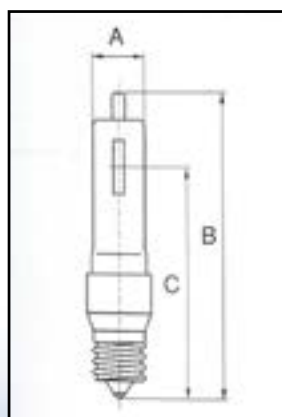

Fig-1

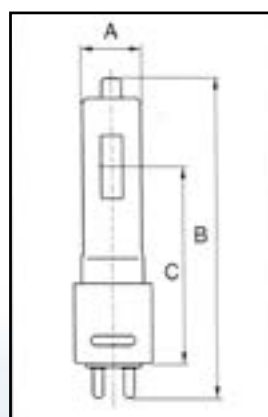
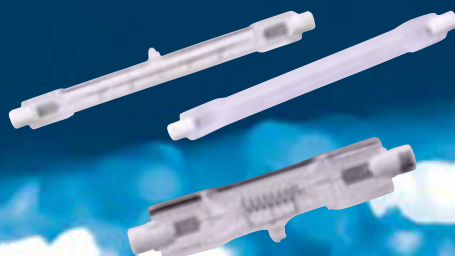

Fig-2

J. JP. JPD

両口金タイプ



R7s,RX7s Base

品名	ANSI	定格電圧(V)	消費電力(W)	寸法 (mm)			全光束 (lm)	色温度 (K) 参考値	定格寿命 (h)	BASE	フィラメントタイプ	Fig.No.
				A(Max.)	B(Max.)	C						
J 100V 150W		100	150	119.6	114.2	9	2400	2900	2000	R7s	C-8	1
J 100V 300W		100	300	119.6	114.2	9	6000	2950	2000	R7s	C-8	1
J 100V 500W		100	500	119.6	114.2	12	11000	3000	2000	R7s	C-8	1
* J 220V 300W		220	300	119.6	114.2	9	5000	2900	2000	R7s	C-8	1
JP 100V 300W C		100	300	119.6	114.2	12	7500	3200	100	R7s	C-8	1
JP 100V 500W B		100	500	119.6	114.2	12	11000	3050	500	R7s	C-8	1
JP 100V 500W C		100	500	119.6	114.2	12	13000	3200	200	R7s	C-8	1
JP 100V 500W BF ※		100	500	119.6	114.2	12	10700	3050	500	R7s	C-8	1
JP 100V 500W CF ※		100	500	119.6	114.2	12	12700	3200	200	R7s	C-8	1
JP 100V 750W B		100	750	119.6	114.2	12	15800	3050	1000	R7s	C-8	1
JP 100V 750W C		100	750	119.6	114.2	12	19800	3200	400	R7s	C-8	1
JP 100V 750W BF ※		100	750	119.6	114.2	12	15500	3050	1000	R7s	C-8	1
JP 100V 750W CF ※		100	750	119.6	114.2	12	19500	3200	400	R7s	C-8	1
* JP 100V 1000W B		100	1000	119.6	114.2	12	23000	3050	500	R7s	C-8	1
* JP 100V 1000W C		100	1000	119.6	114.2	12	27000	3200	150	R7s	C-8	1
* JP 100V 1000W BF ※		100	1000	119.6	114.2	12	22500	3050	500	R7s	C-8	1
* JP 100V 1000W CF ※		100	1000	119.6	114.2	12	26500	3200	300	R7s	C-8	1
JPD 100V 300W C		100	300	80.3	74.9	15	7500	3200	150	R7s	CC-8	2
JPD 100V 500W C		100	500	80.3	74.9	15	12500	3200	150	R7s	CC-8	2
* JPD 100V 650W C		100	650	80.3	74.9	15	16200	3200	150	R7s	CC-8	2
* JPD 100V 1000W C		100	1000	95	89.6	18	28000	3200	100	R7s	CC-8	2
* JPD 100V 1000W B/L		100	1000	109.5	104.1	18	21000	3050	800	R7s	CC-8	2
* JPD 100V 1000W C/L		100	1000	109.5	104.1	18	25000	3200	200	R7s	CC-8	2
* JPD 120V 650W C	FAD	120	650	80.3	74.9	15	16500	3200	100	R7s	CC-8	2

※フロストバルブ

* 印製品はロット受注生産品です。

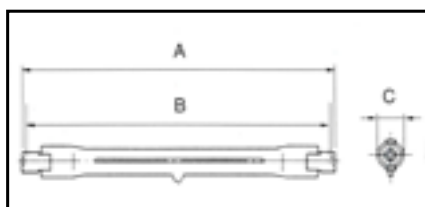

Fig-1

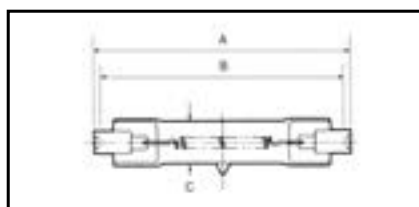

Fig-2